

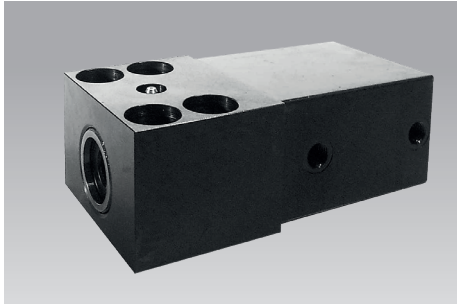

Block Cylinder with Guide Housing

max. operating pressure 500 bar, extending 500 bar steel block cylinder, 350 bar aluminium block cylinder, retracting 350 bar all versions



Description

The hardened clamping bolt is located in a guide housing, and is connected to the flange-mounted block-cylinder by means of a coupling.

The following variants are available

1. Block cylinder as per data sheet B1.5094 without position monitoring
2. Block cylinder as per data sheet B 1.552 with extended piston rod for position monitoring with inductive proximity switches.
3. Block cylinder as per data sheet B 1.554 with magnetic piston and aluminium housing for position monitoring with magnetic sensors.

Advantages

- 4 sizes with different strokes
- 3 block cylinder variants with and without position monitoring
- Standard FKM seals
- Max. environmental temperature as per version up to 150°C
- Position monitoring up to 120°C environmental temperature (see accessories)
- Separation of the function "force generation" and "guiding"
- Clamping bolt compensates high transverse forces
- Clamping bolts can be greased
- Cylinder piston protected by guide housing
- Guide housing protected by sturdy wiper
- The distance of the block cylinder to the effective point allows application in more arduous applications, e.g. welding fixtures
- Hydraulic ports and position monitoring can be mounted at the right-hand side or at the left-hand side

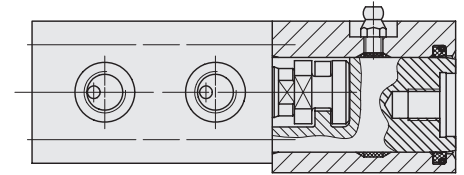

Variants

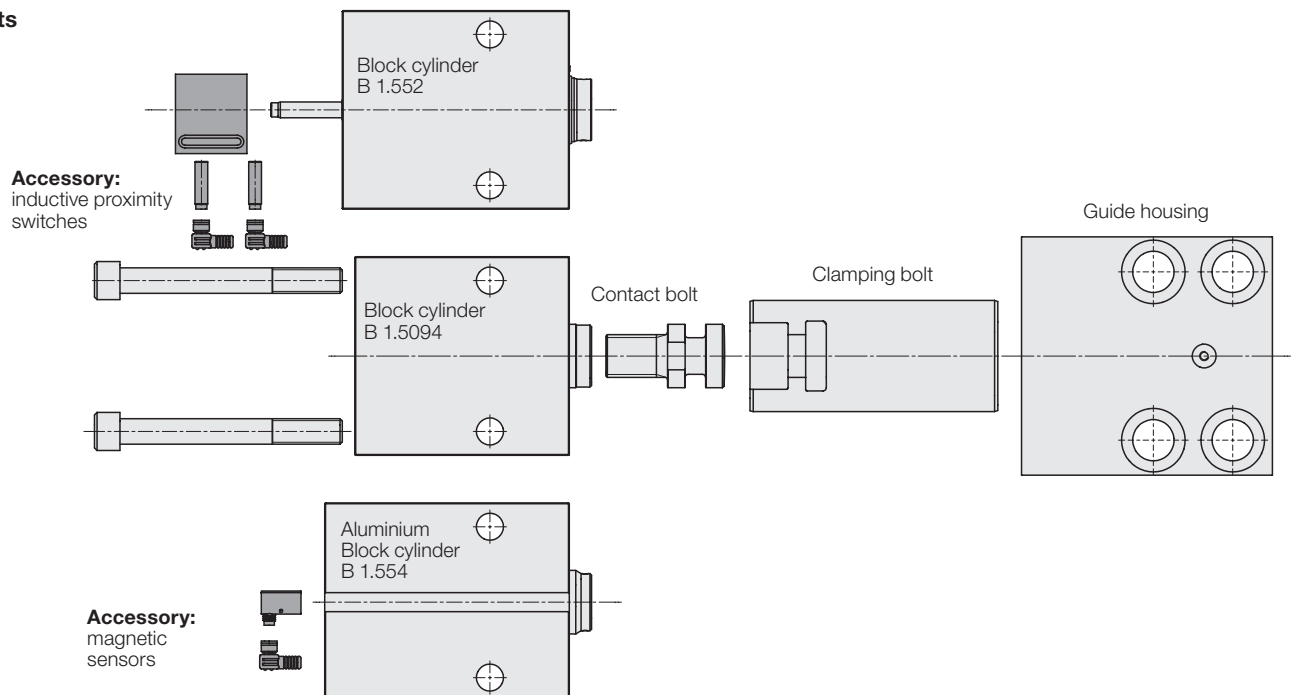



**Block cylinder as per data sheet B 1.552
with extended piston rod and guide housing**

Accessory: position monitoring see page 4

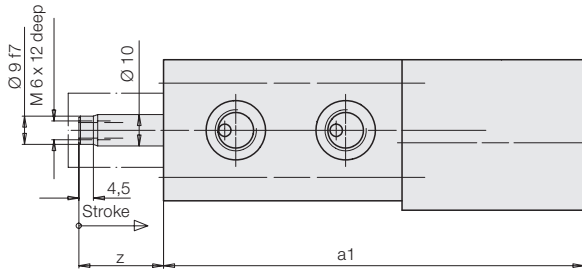

Max. operating pressure
Extend 500 bar
Retract 350 bar

**Block cylinder as per data sheet B 1.5094
with guide housing**

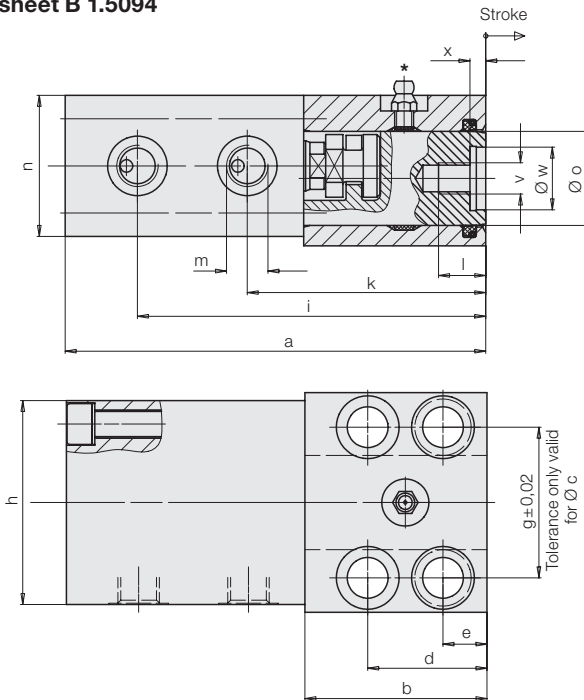

only for 173803X and 173806X

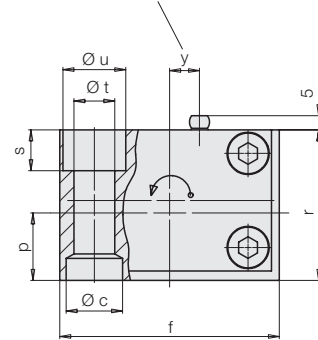

The block cylinder can be turned by 180°

Max. operating pressure
Extend 500 bar
Retract 350 bar

**Aluminium block cylinder as per data sheet B 1.554
with guide housing**

Accessory: magnetic sensors see page 5

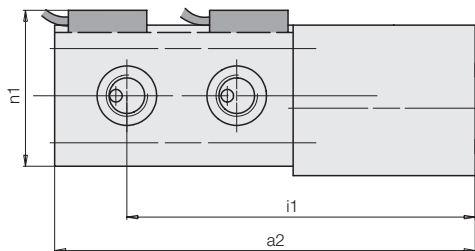

Max. operating pressure 350 bar

Important notes

1. All variants

The guide housing is equipped with a lubricating nipple, so that the clamping bolts can be lubricated with high-temperature grease according to the operating conditions. For this purpose the clamping bolt must be retracted in off-position. Lubrication intervals must be adapted to existing operating conditions.

– Throttling of the flow rate

Throttling has to be made in the oil supply line to the block cylinder to rule out a possible pressure intensification and thereby pressures over 350 bar. The hydraulic circuit diagram shows flow control valves which allow oil return from the block cylinder without any impediments.

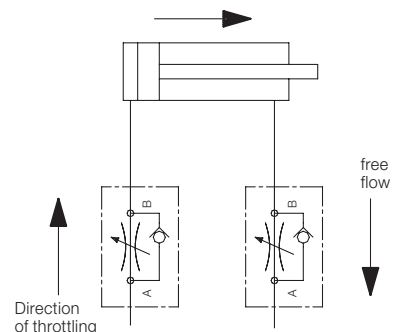

Dimensions block cylinder with guide housing

Piston Ø	[mm]	25	25	40	40	50	50	63	63
Stroke	[mm]	20	50	25	50	25	50	30	63
a	[mm]	122	182	157	207	190	240	227	293
a1	[mm]	134	194	168	218	200	250	235	-
a2	[mm]	136	196	174	224	207	257	246	312
b	[mm]	58	88	78	103	100	125	125	158
Ø c H7xdepth	[mm]	18/7	18/7	26/9	26/9	30/11	30/11	35/11	35/11
d	[mm]	38	38	46	46	58	58	75	75
e	[mm]	14	14	16	16	20	20	25	25
f	[mm]	70	70	95	95	120	120	150	150
g	[mm]	48	48	65	65	85	85	106	106
h	[mm]	65	65	85	85	100	100	125	125
i	[mm]	111	171	146	196	177	227	210	276
i1	[mm]	118	178	153	203	186	236	220	286
k	[mm]	76	106	102	127	127	152	151	184
l	[mm]	18	18	25	25	30	30	40	40
m		G 1/4	G 1/4	G 1/4	G 1/4	G 1/4	G 1/4	G 1/2	G 1/2
n	[mm]	45	45	63	63	75	75	95	95
n1	[mm]	57	57	75	75	87	87	107	107
Ø o	[mm]	30	30	40	40	55	55	70	70
p	[mm]	21,5	21,5	28	28	37	37	49	49
r	[mm]	48	48	65	65	80	80	105	105
s	[mm]	13	13	18	18	20	20	25,5	25,5
Ø t	[mm]	13	13	17	17	21	21	26	26
Ø u	[mm]	20	20	26	26	32	32	40	40
v	[mm]	M 10	M 10	M 16	M 16	M 20	M 20	M 27	M 27
Ø w H7	[mm]	20	20	32	32	40	40	50	50
x	[mm]	5	5	5	5	5	5	5	5
y	[mm]	9,5	9,5	-	-	19	19	-	-
z	[mm]	27	57	32	57	32	57	37	-
Max. circumferential backlash guide bolt +/-	[°]	17	17	8	8	6	6	10	10
4 off screws DIN 912-8.8*	[mm]	M 12	M 12	M 16	M 16	M 20	M 20	M 24	M 24
Required tightening torque	[Nm]	86	86	210	210	410	410	710	710
Accessory , for drill bushing DIN 179	[mm]	A 12 x 12	A 12 x 12	A 17 x 16	A 17 x 16	A 21 x 20	A 21 x 20	A 26 x 20	A 26 x 20
Part no.		3300285	3300285	3300287	3300287	3300288	3300288	3300289	3300289

Block cylinder with extended piston rod and guide housing

Part no.		1738330	1738336	1738350	1738356	1738360	1738366	1738370	
Max. clamping force at 500 bar F	[kN]	20,6	20,6	58,9	58,9	94,2	94,2	152	
Weight	[kg]	2,5	3,9	5,7	7,7	7,6	10,5	14,8	

Accessory, position monitoring see page 4

Block cylinder with guide housing

Part no.		1738030	1738036	1738050	1738056	1738060	1738066	1738070	1738076
Max. clamping force at 500 bar F	[kN]	24,5	24,5	62,8	62,8	98,5	98,5	156	156
Weight	[kg]	2,4	3,8	5,6	7,6	7,5	10,4	14,7	20,8

Aluminium block cylinder with guide housing

Part no.		1738130	1738136	1738150	1738156	1738160	1738166	1738170	1738176
Max. clamping force at 350 bar F	[kN]	17,1	17,1	44	44	68,7	68,7	109,2	109,2
Weight	[kg]	2,14	2,36	4,4	5,9	5,74	8,05	12	16,1

Accessory, magnetic sensors see page 5

* included in the delivery

Article available on request

On request, we will check whether the article is still available.

2. Block cylinder with extended piston rod

Inductive position monitoring systems, which can be delivered as accessory, are not suitable for applications where coolants are used. Additional covers also have to be provided against swarf.

3. Block cylinder with aluminium housing

Please use only fittings with soft seals (see accessories page 5).

Block cylinders with aluminium housing are not suitable for operation of blanking and punching dies. Uncontrollable spikes and vibrations can appear which especially in the case of aluminium could cause a decrease in tool life. Steel can influence the magnetic field of the magnetic piston and thereby the position of the switching points. If there is the same influence for each stroke (e.g. because of adjoining steel

components) it can be compensated by displacing the magnetic sensors. But if the influence differs from stroke to stroke, as e.g. in the case of swarf, a cover has to be provided 30 mm over the magnetic sensors. Covers have to be provided to protect the cylinders against ferritic swarf.



Description

The position monitoring will be screwed on the cylinder bottom and can also be mounted in a position rotated by 180°. Different versions are available according to the application conditions. A control cam is provided at the extended piston rod causing the activation of the proximity switches. The adjustment of the switching position is effected by a displacement of the proximity switches in the lateral groove. The proximity switches are switched on in a stroke range of approx. 6 mm by means of the control cam. The minimum distance to the positions to be monitored depends on the switch type and is indicated in the table.

Function

1. Signal – unclamped position, i.e. piston rod is retracted
2. Signal – clamped position, i.e. piston rod is extended and is in the clamped area

Important notes

The position monitoring system is not suitable for applications where coolants are used. Additional covers also have to be provided against swarf.

Designing – Application Conditions – Safety Measure

Careful design is required, the corresponding application conditions and safety measures have to be planned and guaranteed.

Please do not hesitate to contact us for further information.

Electric circuit diagram

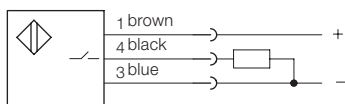

Technical data for inductive proximity switches

Voltage UB	10 ... 30 V DC
Ripple	max. 15%
Switching function	closing
Basic technology	PNP
Material of housing	stainless steel
Code class according to DIN 40050	IP 67

Typ A

Standard version

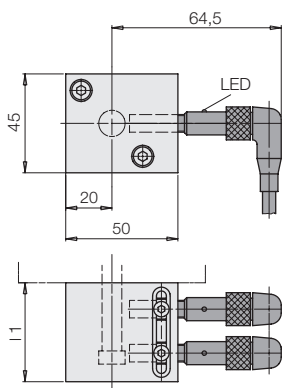

Typ B

Compact version

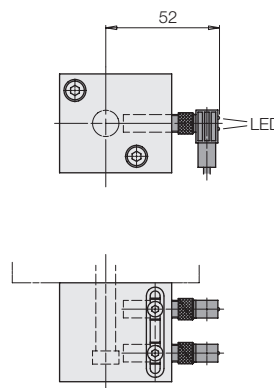

Typ C

for high environmental temperature

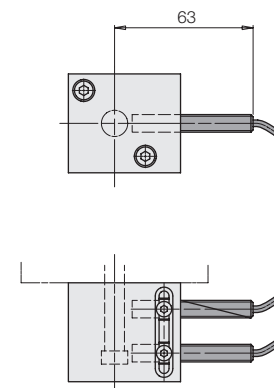

Environmental temperature TA		-25° ... +70 °C	-25° ... +70 °C	-25° ... +120 °C
Min. distance of the switching positions [mm]		13	8	8
Connection type		Plug	Plug	Teflon cable 3 x 0.14 mm ²
LED function display		in the switch	in the plug	No
Max. constant current [mA]		200	100	200 – ab 70°:100
Nominal switch distance [mm]		1,5	1,5	2
Short circuit proof		Yes	Yes	No
Connection cable [m]		5	5	3
Proximity switch	Part no.	3829077	3829263	3829087
Plug with cable	Part no.	3829088	3829099	–
L1 complete [mm]		45	45	45
Position monitoring up to 30 mm total stroke	Part no.	0382300	0382301	0382302
L1 complete [mm]		65	65	65
Position monitoring up to 50 mm total stroke	Part no.	0382310	0382311	0382312

Position monitoring without proximity switches

In case of use of own inductive proximity switches the switching unit M 8x1 is also available without proximity switches.

Required dimensions:

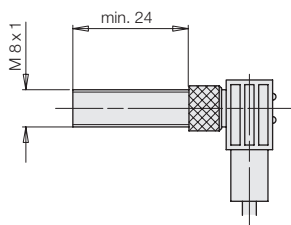

	Part no.
Total stroke [mm] up to 30	0382303
Total stroke [mm] up to 50	0382313

Compared with traditional reed switches the electronic magnetic sensors offer the following advantages:

- Indifference to shock and vibration
- Bounce-free output signal
- Only one switching point
- Wear resistant
- Protection against reverse battery
- Protected against short circuits

Electric connection is made as per traditional inductive proximity switches; up to four magnetic sensors can be connected in series.

Minimum distance of the switching points: 6 mm.

For further information about voltage supply for position controls see data sheet G 2.140.

Electronic magnetic sensor

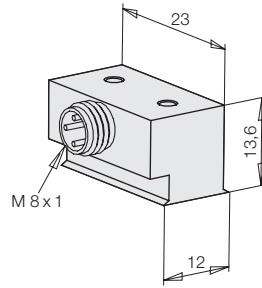

Temperature curve

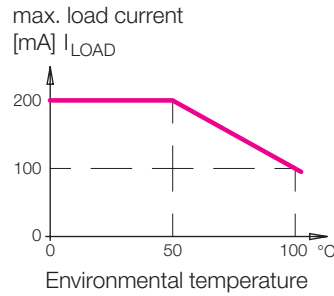

Connecting cable with right angle plug

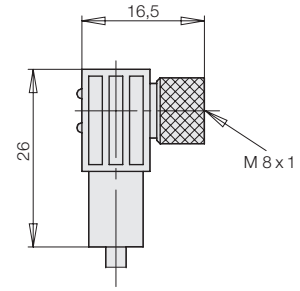

Connecting scheme

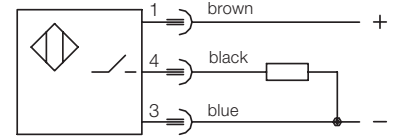

pnp (+) switching

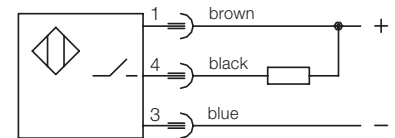

npn (-) switching

Technical data	Electronic magnetic sensor	Connecting cable with right angle plug
Cylinder body material	aluminium black lacquered	
Voltage	10 – 30 V DC	10 – 30 V DC
Residual ripple	max. 10%	
Current load I _{LOAD}	200 mA – up to 50 °C 150 mA – at 75 °C 100 mA – at 100 °C	
Current consumption	< 15 mA	
Voltage drop (max. load)	< 2 V	
Protected against short circuits	yes	
Protection against reverse battery	installed	
Switching frequency	1 kHz	
Switching hysteresis	3 mm	
Protection as per DIN 40050	IP 67	IP 67
Environmental temperature	-25 °C up to +100 °C	-25 °C up to +90 °C
Plug connection	M8-plug	M8-plug
LED	no	Voltage (green) Function display (yellow)
Cable, length of cable		PUR, 5 m
Output, interlock	pnp	nnp
Part no. (1 off)	3829234	3829240
		pnp
		nnp
		3829099
		3829124

Max. cylinder temperature

Hydraulic fluid	Cylinder temperature	without magnetic sensor	
		Perbunan	FKM
HLP	-25 ... +100 °C	-25 ... +100 °C	-20 ... +120 °C
HFD			-20 ... +120 °C

Further accessory

see data sheet G 2.140

- Pin-and-socket connector
- Y-distributor
- Reversing plug
- Voltage regulator
- Straight tube male stud coupling with elastic sealing

Type L
D 8 L ED for tube Ø 8 G 1/4 250 bar
D 15 L ED for tube Ø 15 G 1/2 250 bar

Part no.
9208131
9215033

Type S
D 8 S ED for tube Ø 8 G 1/4 350 bar
D 16 S ED for tube Ø 16 G 1/2 350 bar

Part no.
9208132
9216021



Other fittings see data sheet F 9.300

Coupling fixture

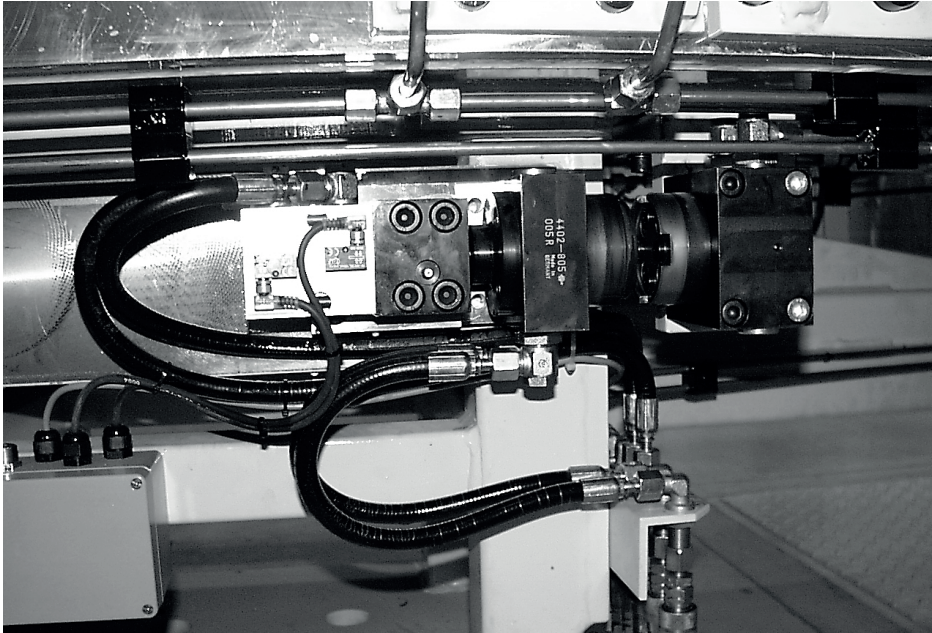

Position monitoring



Position monitoring with inductive proximity switches

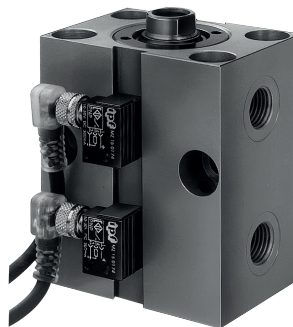

Position monitoring
with magnetic sensors